

Copperhead Desktop Full-Range Speaker Kit Pair

Thank you for purchasing the Copperhead Desktop Speaker Kit pair. This kit was precision cut using CNC machinery for the best possible fit and finish. With a little time and patience, your finished product will provide years of enjoyment. Please use the following instructions for the best possible results.

Suggested tools and consumables:

Drill	Rag or paper towels
5/64" drill bit	Solder
Wood clamps (you can never have too many of these)	Soldering iron
Sanding block and/or electric finishing sander	Wood glue
Speaker or hook-up wire (14-16 gauge)	Binding post/terminal cup
Pencil or Sharpie marker	Phillips screwdriver
#6 x 3/4" Pan head wood screws	

Package contents:

First, empty the contents of the package and review parts to ensure everything has been included and is in good condition. If any parts are missing or damaged please contact our customer service department at 1-800-338-0531.

Components:



- A) 2 x Dayton Audio PS95-8 3-1/2" Point Source Full Range Driver 8 Ohm
- B) 1 x Speaker Cabinet Port Tube 1" ID x 4" L Flared

Enclosures:

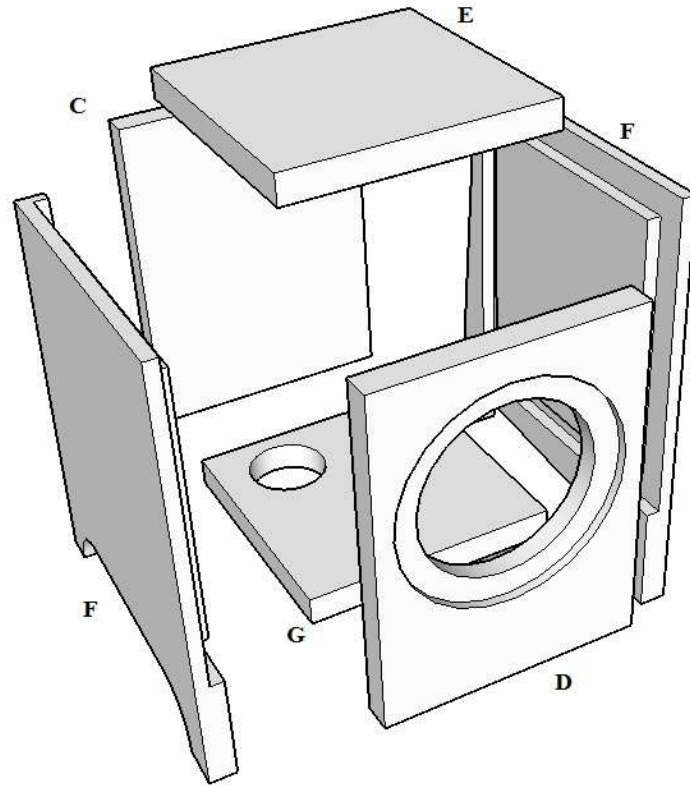

- C) 2x Back
- D) 2x Front
- E) 2x Top
- F) 4 x Sides
- G) 2x Bottom

Notch Filter Components:



- H) 2x Dayton Audio DNR-16 16 Ohm 10W Precision Audio Grade Resistor
- I) 2x 12 uF 100V Electrolytic Non-Polarized Crossover Capacitor
- J) 2x Dayton Audio AC20-60 0.60mH 20 AWG Air Core Inductor Coil
- K) 2x Dayton Audio LW18-22 0.22mH 18 AWG Perfect Layer Inductor

Enclosure Assembly:

- 1) First, take either the back or bottom panel and cut or drill holes required for the speaker termination of your choice (binding posts, terminal cup, Speakon, etc...).

NOTE: The down-firing ports are offset to one side on these enclosures. Keep this in mind when you drill for your terminals so you do not interfere with the ports once they are installed.

- 2) Next, set the enclosure parts out on a flat level surface and ensure that all pieces are free of dust and debris.
- 3) With one side panel lying flat, glue all mating surfaces of each panel in the order shown below. Due to the placement of dado cuts, these cabinets should require only a few clamps for assembly and gluing.

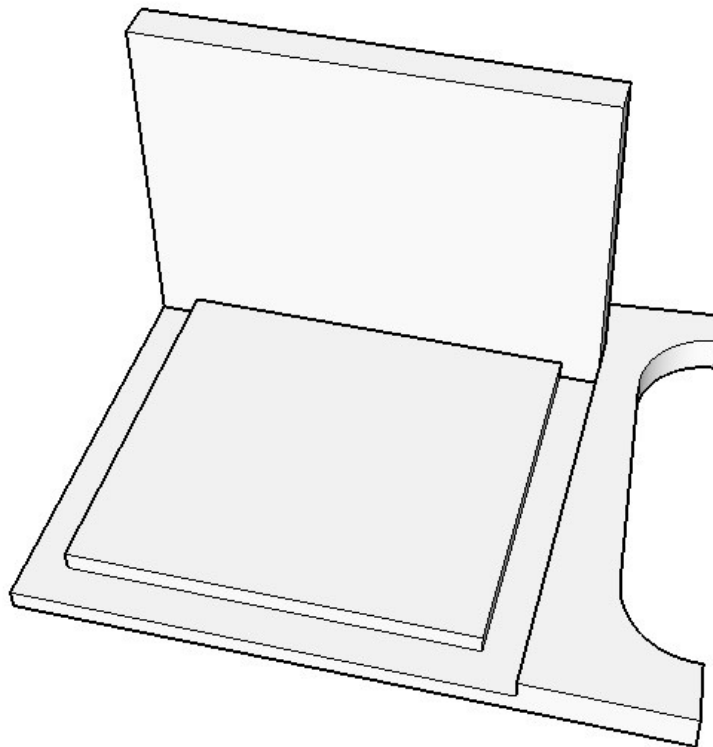

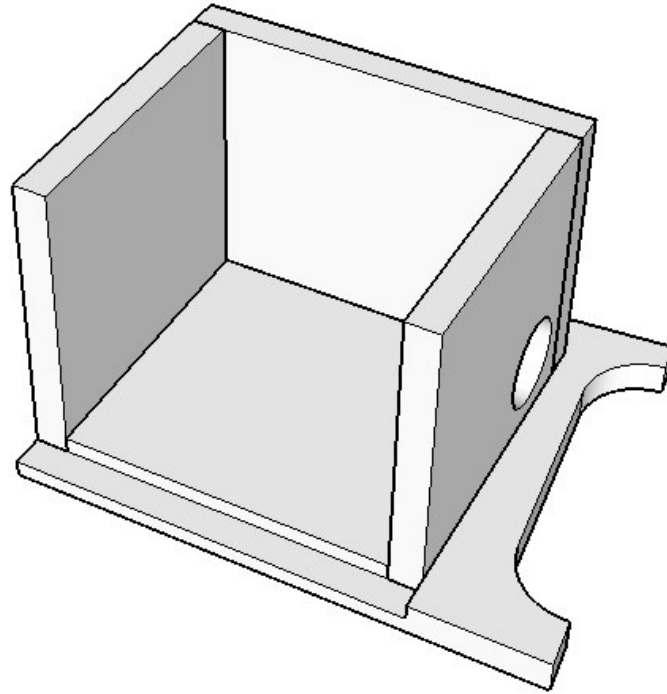

NOTE: The port opening on the bottom is not equidistant to each side of the panel. In order for the port to fit once the cabinet is complete, the larger gap next to the port opening needs to be against the side of the cabinet as shown below, not the back.

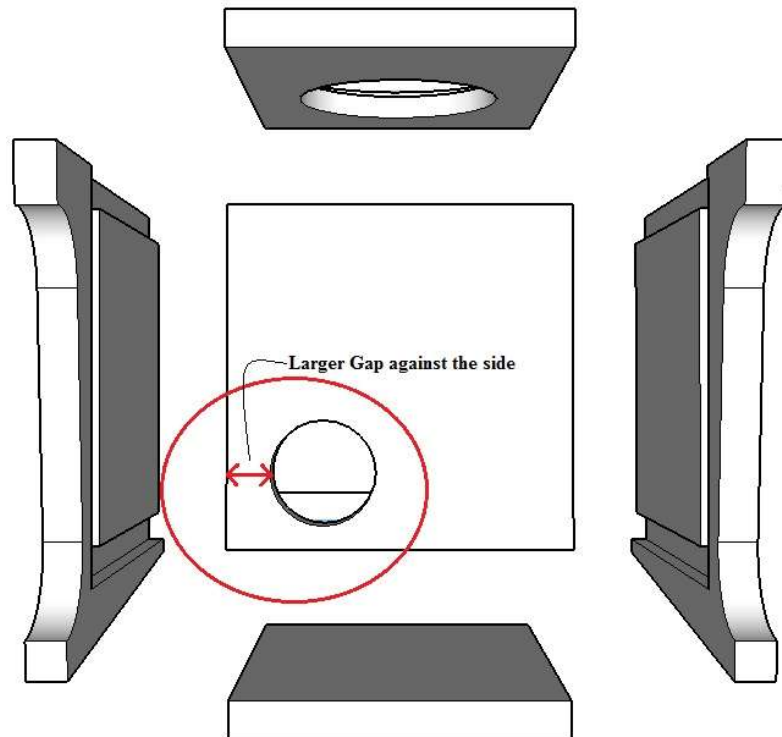

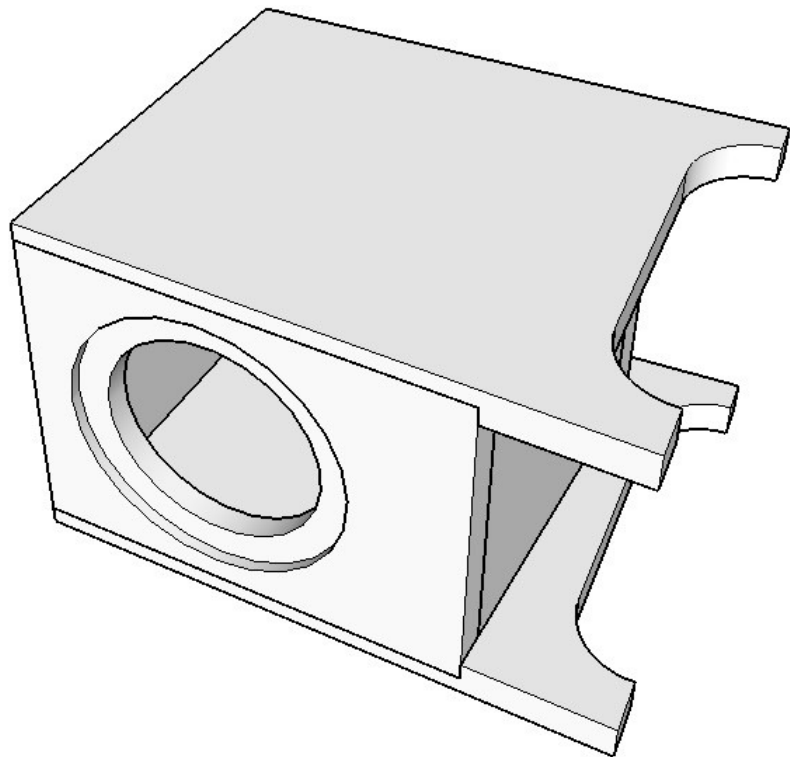
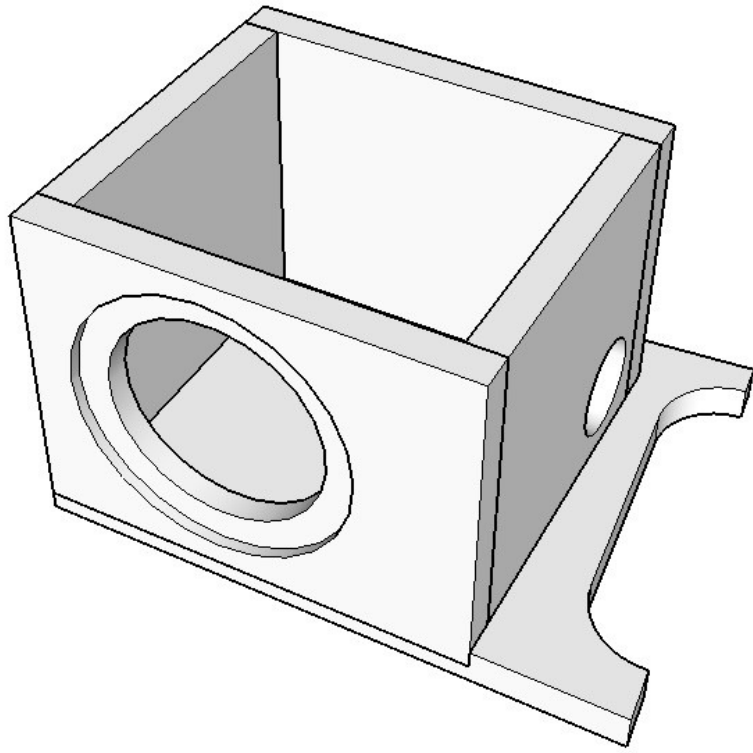

- 4) Make sure all mating surfaces have flush edges and stand the enclosure up on its legs. Apply one clamp from side to side and two clamps from front to back at the top and bottom.
- 5) Using a damp rag or paper towel, wipe away any glue squeeze-out on the outside of the enclosure (excess glue on the inside is fine). Allow to dry according to the glue manufacturer's recommendations and remove clamps.
- 6) Sand and finish enclosure to your liking. See our web page for examples.

Notch Filter Assembly:

These speakers include notch filters to provide a smooth, fatigue free listening experience. The main filter includes three components wired in parallel with each other, with all three wired in series to the PS95 driver:

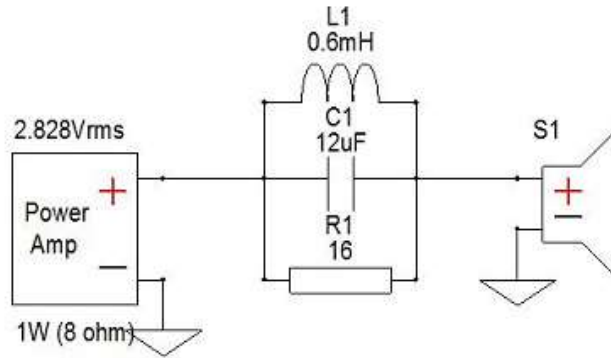

The notch filter flattens the rise caused by baffle step as can be seen below. Black is no filter, red is with the notch.

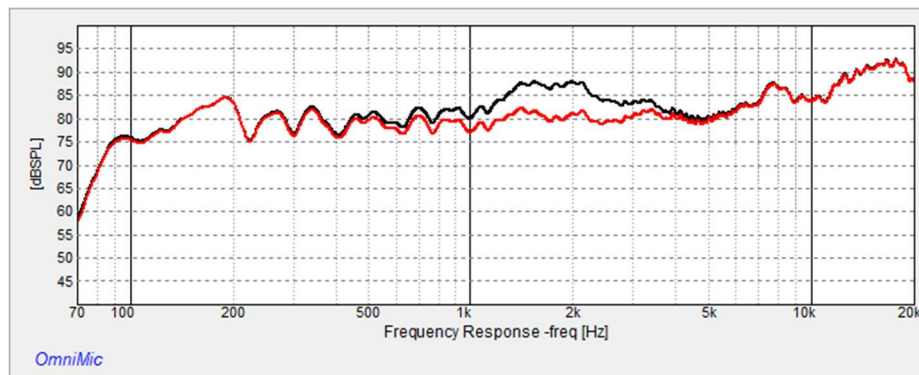

Wiring Diagram:

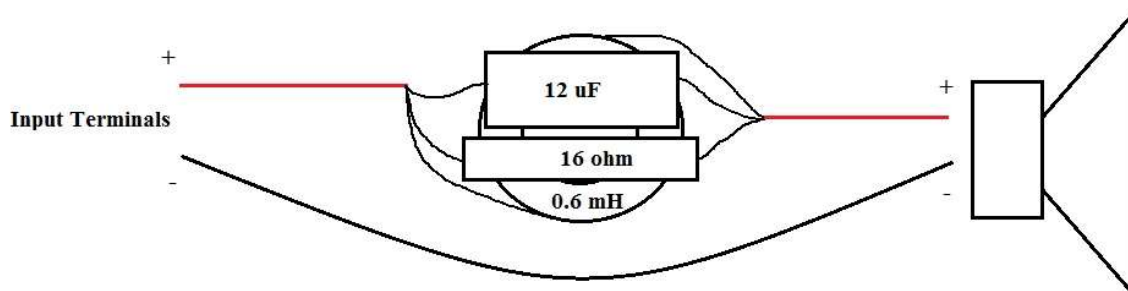

Optional Treble Attenuation

The addition of the L2 inductor is optional in this design. This will help flatten the rising treble response and is recommended for near field or on-axis listening applications.

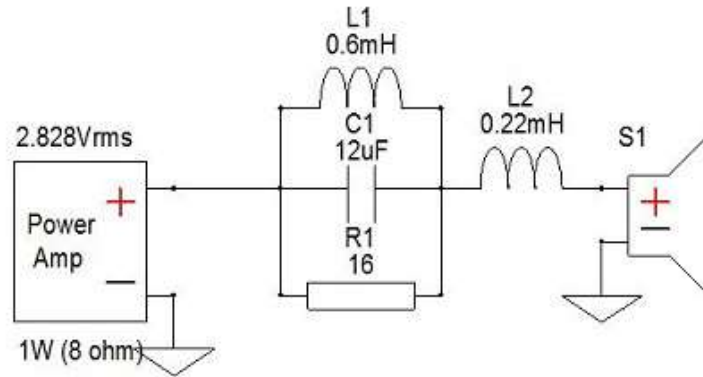

You can see the difference with and without L2 in the response below. Red is with L2, black is without.

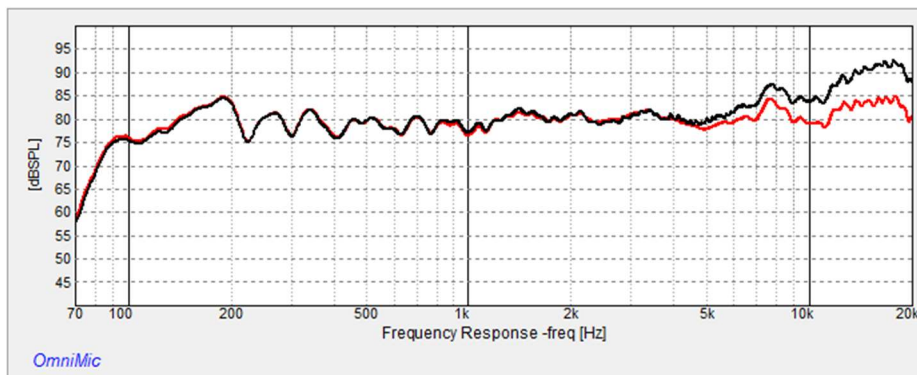

Wiring Diagram:

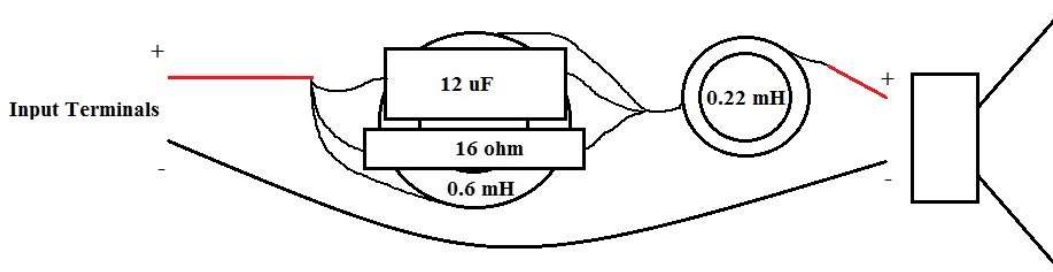

Final Assembly:

- 7) Once the filters are assembled, solder these to the input terminals of your choice and install the terminals. Hot glue the notch filter to the inside of the enclosure. Be sure not to glue it over the port opening. Leave about 5" of wire slack for connecting to the PS95 driver.
- 8) Place the PS95 in its recessed cutout and mark the screw holes with a sharpie or pencil. Remove the driver and pilot drill these marks using your 5/64" drill bit. Clean up the resulting sawdust.
- 9) Install press-fit port tubes by pressing them in place on the bottom of the enclosures.
- 10) Install your choice of sound damping material. We recommend a hand full of Acousta-Stuf (part number 260-317) or lining the interior walls with our 1/2" Sonic Barrier peel and stick foam (part number 260-520).
- 11) Connect the wire from the notch filter to the PS95, observing proper polarity.
- 12) Install the PS95 using a hand screwdriver. We do not recommend using a power drill for this because it can easily slip and damage the driver cone or surround.
- 13) You are now ready to enjoy your finished Copperhead Full Range kit!

